

INCLINATOR ELEVETTE[®]

Planning Guide

**CABLE DRUM
950 lb.**

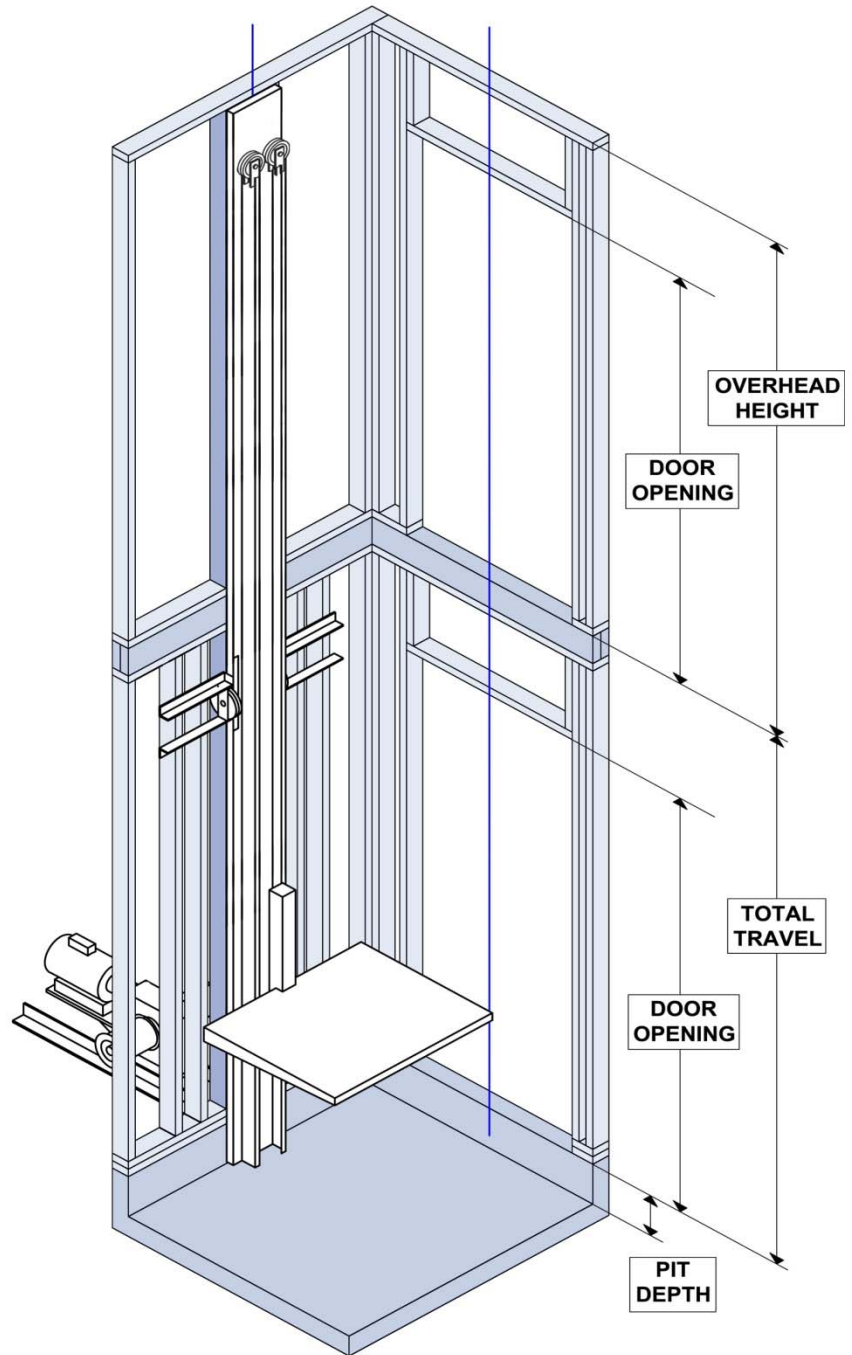

AMERICA'S MOST CUSTOMIZABLE ELEVATOR



Introduction

It started over 85 years ago with a passion to help an ailing friend access his multi-level home. Now, almost a century later, the Inclinor craftsmanship can be found in more American homes today than any other brand. We want to use our heritage of service to enhance each stage of your building or remodeling experience and to help you create a uniquely personalized elevator for your home.

Of all the stages, none is quite as exciting as the initial design phase. It's where you begin to imagine the possibilities of something that's uniquely yours. A home is personalized by the components you choose to fit your needs.

Our Planning Guide is designed to simplify and assist architects, contractors, home owners and dealers in planning for a home elevator that meets the requirements of ASME A17.1

We recommend you contact an authorized dealer in the area where the elevator will be installed. They will be knowledgeable about local codes and restrictions. Become familiar with all requirements governing the installation and use of elevators in private residences. It is extremely important for you to know and adhere to all regulations concerning installation.

This Planning Guide provides nominal dimensions and specifications useful for the *initial* planning of an elevator project. Before beginning actual construction, be sure to contact a local authorized dealer and obtain approval drawings customized with specifications and dimensions for your specific project. Call 1-800-343-9007 to find a local dealer or visit our website, www.inclinor.com. Inclinor elevators manufactured and installed under the proper parameters are warranted for 2 years. We assume no liability for equipment not installed in compliance with national, state, and local codes.



Table of Contents

Hoistway Layout.....	4-8
Hoistway Construction	9
Hoistway Specifications	10
Hoistway Elevation.....	11
Pit Specifications.....	12
Technical Specifications.....	12
Machine Room Specifications.....	13
Sheave Configurations.....	14-16
Gearbox Assembly.....	17
Travel Sheaves	17
Warranty.....	18

Steps of planning for an Inclinator Elevette

1. Locate local dealer and together determine the following:
 - a. Select a drive system, cab type and design specifications
 - b. Address national, state and local code requirements
 - c. Determine installation parameters of site
2. Obtain approval drawings before building hoistway, doorways, pit and any other construction related to the elevator
3. Coordinate with dealer to order and install the elevator



Hoistway Layout

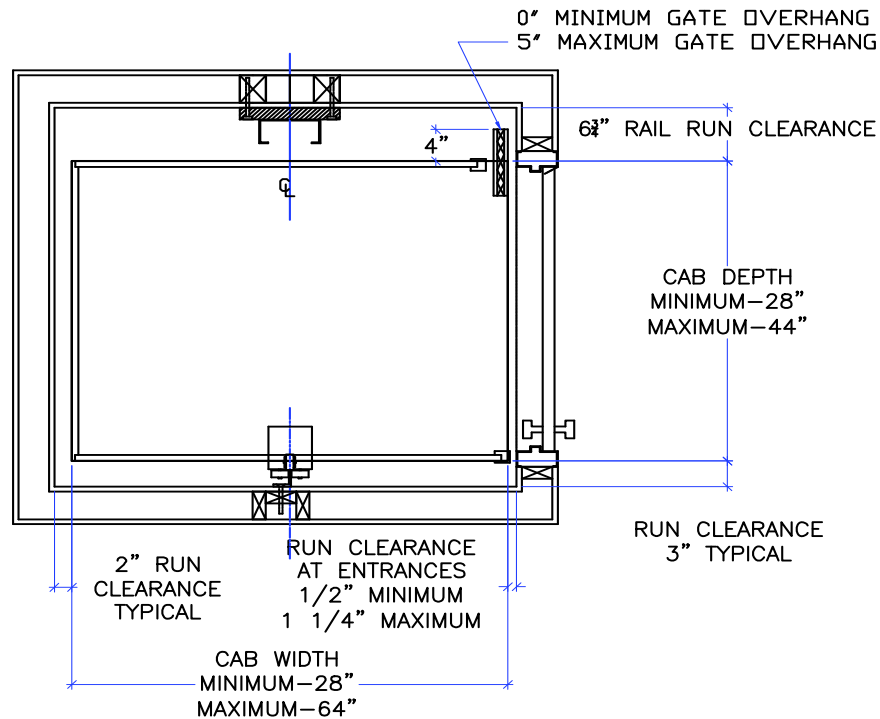

The data indicating minimum and maximum sizes is applicable to all 950 lb. models up to 15 sq. ft. interior car dimensions.

The following specs are to be provided by the General Contractor (GC), except as noted, prior to Elevator Contractor (EC) installing the elevator equipment.

1. Enclosed, plumb and square hoistway with smooth interior surfaces. Include for fascias or furring of hoistway interior.
2. Doors, frames and door hardware.
3. Finish openings as per elevator contractor's shop drawings.
4. Jamb boxes shall be flush to finish surface at specified height at each hoistway door.
5. Hoistway door security: All hoistway doors require door locking devices (provided by Inclinator) as well as a door handle and a latch set. All doors must be swing type (single hinge). Solid core doors are recommended.
6. Unfinished/Un-installed door: EC may prefer a minimum of one hoistway door and associated framing be left unfinished to accommodate elevator installation and prevent possible damage to door/framing. Preferably at the lowest floor.



Hoistway Layout

The following data is for typical industry size elevators.

Any size cab is available in ¼" increments to dimensions **A** and **C** or **B** and **D** within the maximum and minimum dimensions shown in the diagram on page 4 not to exceed 15 SQ. FT.



- Applicable to standard size wheelchairs

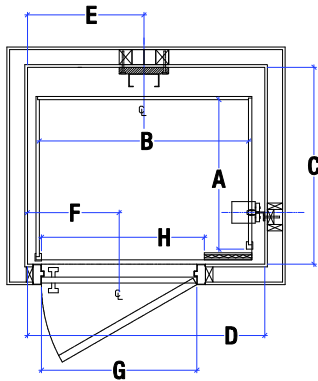

CODE 1

CODE 1	CAR SIZE (O.D.)	A	B	C	D	E	F	G	H
		CAB DEPTH (I.D.)	CAR WIDTH (I.D.)	SHAFT DEPTH	SHAFT WIDTH	CENTER OF RAIL	CENTER OF DOOR	DOOR SIZE	CLEAR OPENING
	38" x 50"	35.75"	48.50"	45.75"	55.00"	27.00"	21.25"	36"	UP TO 38"
	38" x 60"	35.75"	58.50"	45.75"	65.00"	32.00"	21.25"	36"	UP TO 44"
	42" x 48"	39.75"	46.50"	49.75"	53.00"	26.00"	21.25"	36"	UP TO 36"
	42" x 54"	39.75"	52.50"	49.75"	59.00"	29.00"	21.25"	36"	UP TO 44"

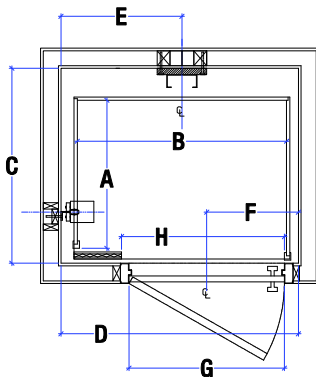

CODE 2

CODE 2	CAR SIZE (O.D.)	A	B	C	D	E	F	G	H
		CAB DEPTH (I.D.)	CAR WIDTH (I.D.)	SHAFT DEPTH	SHAFT WIDTH	CENTER OF RAIL	CENTER OF DOOR	DOOR SIZE	CLEAR OPENING
	38" x 50"	35.75"	48.50"	45.75"	55.00"	28.00"	21.25"	36"	UP TO 38"
	38" x 60"	35.75"	58.50"	45.75"	65.00"	33.00"	21.25"	36"	UP TO 44"
	42" x 48"	39.75"	46.50"	49.75"	53.00"	27.00"	21.25"	36"	UP TO 36"
	42" x 54"	39.75"	52.50"	49.75"	59.00"	30.00"	21.25"	36"	UP TO 44"

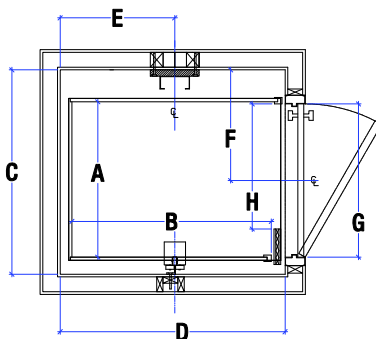

CODE 3

CODE 3	CAR SIZE (O.D.)	A	B	C	D	E	F	G	H
		CAB DEPTH (I.D.)	CAR WIDTH (I.D.)	SHAFT DEPTH	SHAFT WIDTH	CENTER OF RAIL	CENTER OF DOOR	DOOR SIZE	CLEAR OPENING
	38" x 50"	36.50"	47.75"	48.00"	53.00"	27.00"	24.00"	32"	UP TO 30"
	38" x 60"	36.50"	57.75"	48.00"	63.00"	32.00"	24.00"	32"	UP TO 30"
	42" x 48"	40.50"	45.75"	52.00"	51.00"	26.00"	26.00"	36"	UP TO 34"
	42" x 54"	40.50"	51.75"	52.00"	57.00"	29.00"	26.00"	36"	UP TO 34"



Hoistway Layout

The following data is for typical industry size elevators.

Any size cab is available in ¼" increments to dimensions **A** and **C** or **B** and **D** within the maximum and minimum dimensions shown in the diagram on page 4 not to exceed 15 SQ. FT.

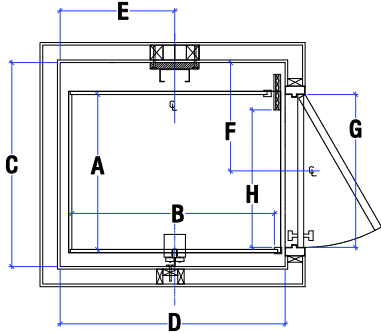

CODE 4

CODE 4	CAR SIZE (O.D.)	A	B	C	D	E	F	G	H
		CAB DEPTH (I.D.)	CAR WIDTH (I.D.)	SHAFT DEPTH	SHAFT WIDTH	CENTER OF RAIL	CENTER OF DOOR	DOOR SIZE	CLEAR OPENING
	38" x 50"	36.50"	47.75"	48.00"	53.00"	27.00"	27.50"	32"	UP TO 32"
	38" x 60"	36.50"	57.75"	48.00"	63.00"	32.00"	27.50"	32"	UP TO 32"
	42" x 48"	40.50"	45.75"	52.00"	51.00"	26.00"	29.00"	36"	UP TO 36"
	42" x 54"	40.50"	51.75"	52.00"	57.00"	29.00"	29.00"	36"	UP TO 36"

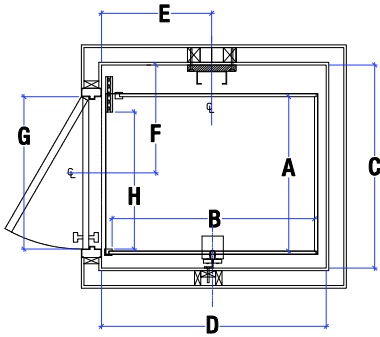

CODE 5

CODE 5	CAR SIZE (O.D.)	A	B	C	D	E	F	G	H
		CAB DEPTH (I.D.)	CAR WIDTH (I.D.)	SHAFT DEPTH	SHAFT WIDTH	CENTER OF RAIL	CENTER OF DOOR	DOOR SIZE	CLEAR OPENING
	38" x 50"	36.50"	47.75"	48.00"	53.00"	26.00"	27.50"	32"	UP TO 32"
	38" x 60"	36.50"	57.75"	48.00"	63.00"	31.00"	27.50"	32"	UP TO 32"
	42" x 48"	40.50"	45.75"	52.00"	51.00"	25.00"	29.00"	36"	UP TO 36"
	42" x 54"	40.50"	51.75"	52.00"	57.00"	28.00"	29.00"	36"	UP TO 36"

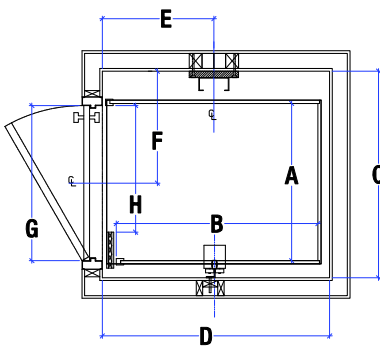

CODE 6

CODE 6	CAR SIZE (O.D.)	A	B	C	D	E	F	G	H
		CAB DEPTH (I.D.)	CAR WIDTH (I.D.)	SHAFT DEPTH	SHAFT WIDTH	CENTER OF RAIL	CENTER OF DOOR	DOOR SIZE	CLEAR OPENING
	38" x 50"	36.50"	47.75"	48.00"	53.00"	26.00"	24.00"	32"	UP TO 30"
	38" x 60"	36.50"	57.75"	48.00"	63.00"	31.00"	24.00"	32"	UP TO 30"
	42" x 48"	40.50"	45.75"	52.00"	51.00"	25.00"	26.00"	36"	UP TO 34"
	42" x 54"	40.50"	51.75"	52.00"	57.00"	28.00"	26.00"	36"	UP TO 34"



Hoistway Layout

CODE 4,5

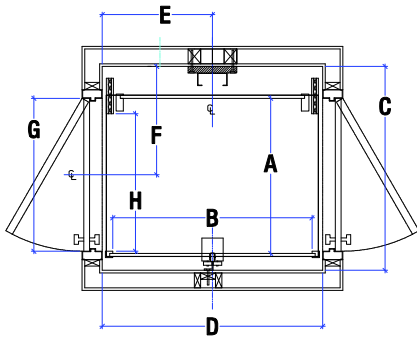

CODE 4,5	CAR SIZE (O.D.)	A	B	C	D	E	F	G	H
		CAB DEPTH (L.D.)	CAR WIDTH (L.D.)	SHAFT DEPTH	SHAFT WIDTH	CENTER OF RAIL	CENTER OF DOOR	DOOR SIZE	CLEAR OPENING
	38" x 50"	36.50"	45.00"	48.00"	52.00"	26.00"	27.50"	32"	UP TO 32"
	38" x 60"	36.50"	55.00"	48.00"	62.00"	31.00"	27.50"	32"	UP TO 32"
	42" x 48"	40.50"	45.00"	52.00"	50.00"	25.00"	29.50"	36"	UP TO 36"
	42" x 54"	40.50"	51.00"	52.00"	56.00"	28.00"	29.50"	36"	UP TO 36"

CODE 3,6

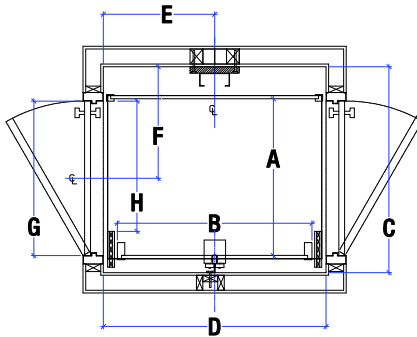

CODE 3,6	CAR SIZE (O.D.)	A	B	C	D	E	F	G	H
		CAB DEPTH (L.D.)	CAR WIDTH (L.D.)	SHAFT DEPTH	SHAFT WIDTH	CENTER OF RAIL	CENTER OF DOOR	DOOR SIZE	CLEAR OPENING
	38" x 50"	36.50"	45.00"	48.00"	52.00"	26.00"	24.00"	32"	UP TO 30"
	38" x 60"	36.50"	55.00"	48.00"	62.00"	31.00"	24.00"	32"	UP TO 30"
	42" x 48"	40.50"	45.00"	52.00"	50.00"	25.00"	26.00"	36"	UP TO 34"
	42" x 54"	40.50"	51.00"	52.00"	56.00"	28.00"	26.00"	36"	UP TO 34"

CODE 5,1

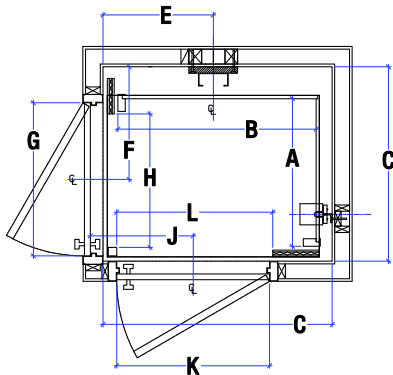

CODE 5,1	CAR SIZE (O.D.)	A	B	C	D	E	F	G	H	J	K	L
		CAB DEPTH (L.D.)	CAR WIDTH (L.D.)	SHAFT DEPTH	SHAFT WIDTH	CENTER OF RAIL	CENTER OF DOOR	ADJ. DOOR	CLEAR OPENING	CENTER OF DOOR	OPP. DOOR	CLEAR OPENING
	38" x 50"	35.75"	47.75"	45.75"	54.00"	26.00"	26.50"	32"	UP TO 32"	21.25"	36"	UP TO 36"
	38" x 60"	35.75"	57.75"	45.75"	64.00"	31.00"	26.50"	32"	UP TO 32"	21.25"	36"	UP TO 36"
	42" x 48"	39.75"	45.75"	49.75"	52.00"	25.00"	28.50"	36"	UP TO 36"	21.25"	36"	UP TO 44"
	42" x 54"	39.75"	51.75"	49.75"	58.00"	28.00"	28.50"	36"	UP TO 36"	21.25"	36"	UP TO 44"

CODE 5,2

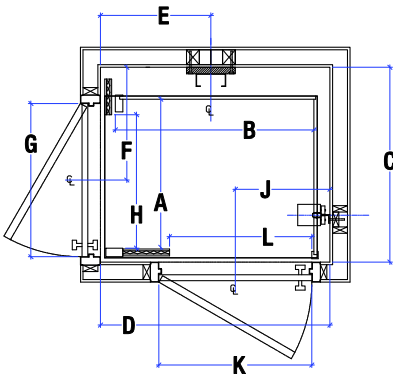

CODE 5,2	CAR SIZE (O.D.)	A	B	C	D	E	F	G	H	J	K	L
		CAB DEPTH (L.D.)	CAR WIDTH (L.D.)	SHAFT DEPTH	SHAFT WIDTH	CENTER OF RAIL	CENTER OF DOOR	ADJ. DOOR	CLEAR OPENING	CENTER OF DOOR	OPP. DOOR	CLEAR OPENING
	38" x 50"	35.75"	47.75"	45.75"	54.00"	26.00"	26.50"	32"	UP TO 32"	22.25"	36"	UP TO 36"
	38" x 60"	35.75"	57.75"	45.75"	64.00"	31.00"	26.50"	32"	UP TO 32"	22.25"	36"	UP TO 36"
	42" x 48"	39.75"	45.75"	49.75"	52.00"	25.00"	28.50"	36"	UP TO 36"	22.25"	36"	UP TO 44"
	42" x 54"	39.75"	51.75"	49.75"	58.00"	28.00"	28.50"	36"	UP TO 36"	22.25"	36"	UP TO 44"



Hoistway Layout

ADDITIONAL CONFIGURATIONS

There are many additional layout options available. Please contact Inclinator or your local dealer for further assistance on shaft configurations.

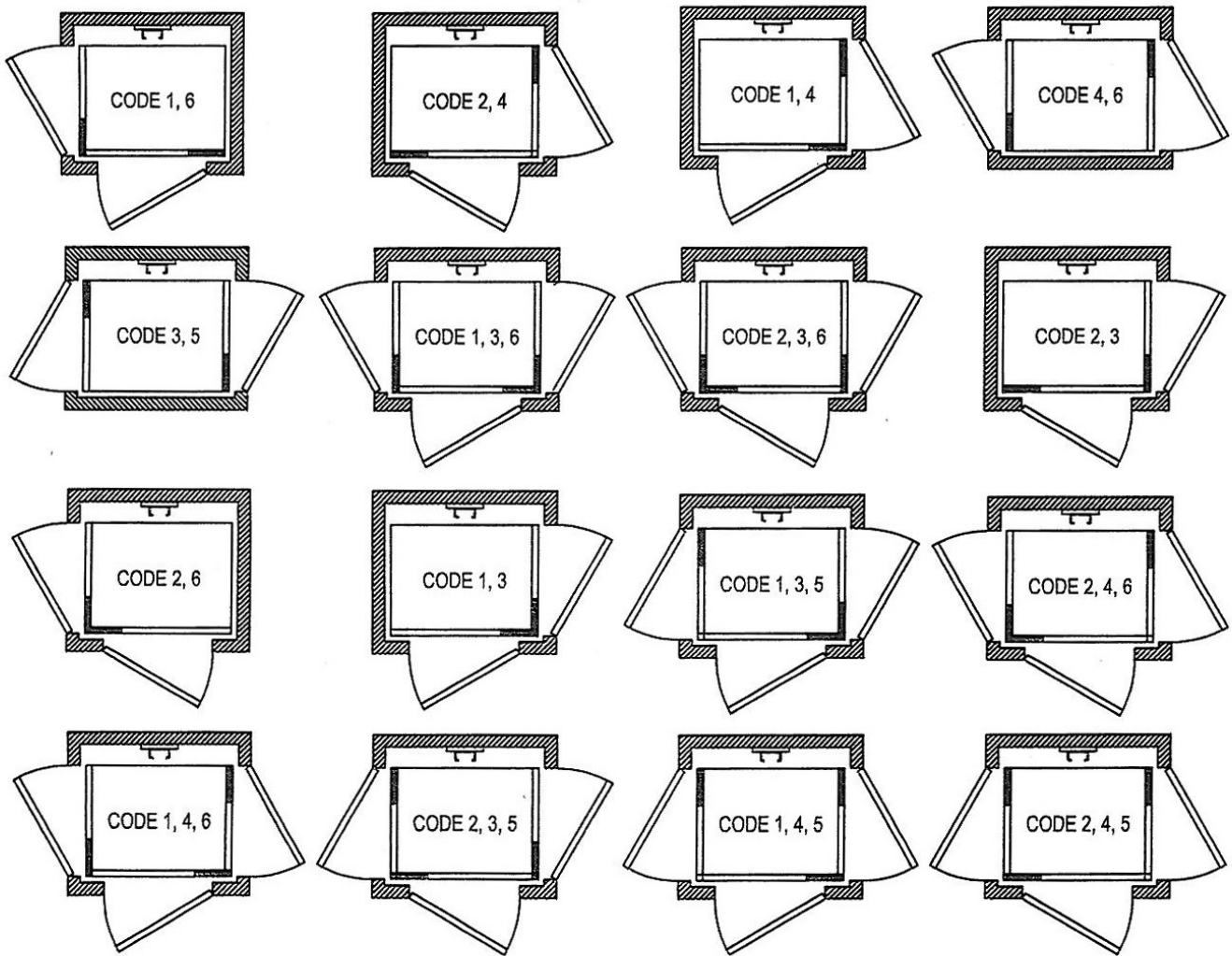

Hoistway Construction

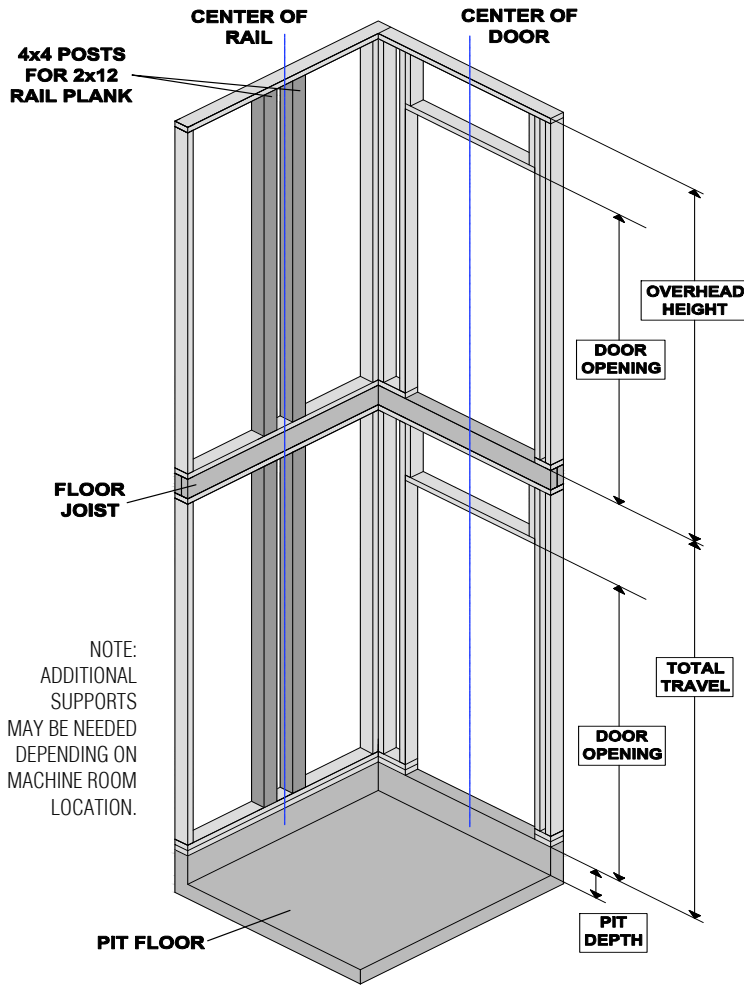

STABILIZER DETAILS

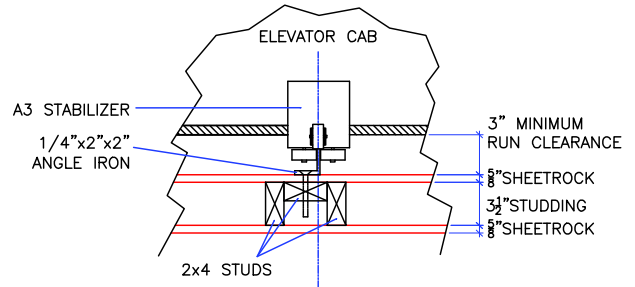

NOTE:
STABILIZER IS MOST COMMONLY PLACED IN MIDDLE OF WALL OPPOSITE THE RAIL. IF THERE IS AN OPENING ON THAT WALL THE STABILIZER MAY BE RELOCATED TO WALL ADJACENT TO THE RAIL.

RAIL DETAILS

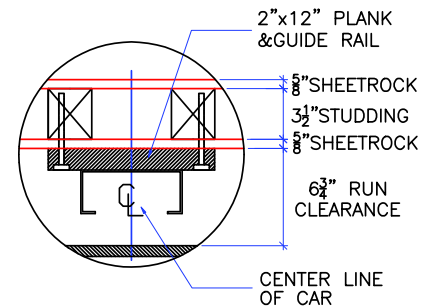

NOTE:
WHEN STUD AND SHEETROCK CONSTRUCTION IS USED ON THE GUIDE RAIL SUPPORT WALL 4"x4" STUDING IS NEEDED BEHIND THE 2"x12" PLANK.

5-3 RULE / DOOR FRAME DETAILS

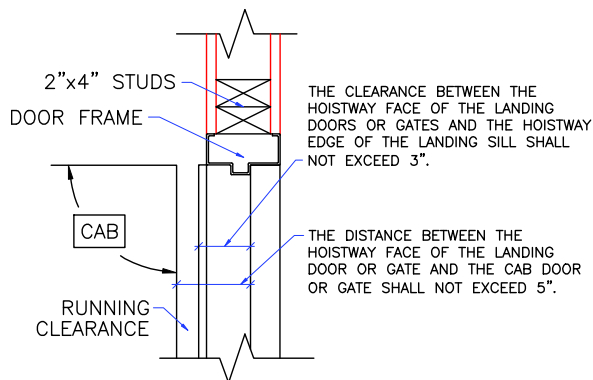

NOTE:
* FRAMING ON DOOR SIDE OF HOISTWAY MUST BE OF 2x4 CONSTRUCTION TO APPLY TO 5-3 RULE OF ANSI 17.1 CODE.

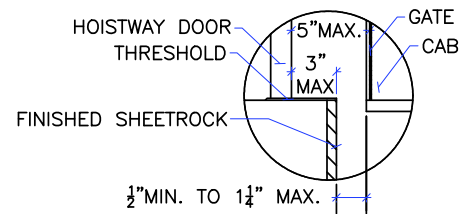

DOOR SILLS TO BE INSTALLED BY GC AFTER THE LIFT SUPPLIER HAS INSTALLED A RUNNING PLATFORM. SILL MUST BE BROUGHT OUT TO NOT LESS THAN 1/2" AND NOT MORE THAN 1 1/4" TO THE RUNNING PLATFORM WHILE MAINTAINING A DISTANCE OF 3" FROM THE HOISTWAY FACE OF THE LANDING DOOR (OR GATE) TO THE HOISTWAY EDGE OF THE LANDING SILL.



Hoistway Specifications

The following specs are to be provided by the General Contractor (GC), except as noted, prior to Elevator Contractor (EC) installing the elevator equipment.

1. **Environmental requirements** for hoistway:
 - a. Temperature should be maintained between 40^o F to 125^o F.
 - b. Should not be exposed to the elements.
2. **Pit Requirements:**
 - a. Substantial level pit floor slab to support 2,700 lbs. impact load.
 - b. Waterproof pit minimum 10" below lowest floor level.
3. **Overhead Requirements:**

DOOR HEIGHT	INSIDE CAB HEIGHT	OVER ALL CAB HEIGHT	OVERHEAD REQUIREMENT
6' - 8"	80"	7' - 0"	8' - 0"
7' - 0"	84"	7' - 4"	8' - 4"
8' - 0"	92"	8' - 0"	9' - 0"
8' - 0"	96"	8' - 4"	9' - 4"

- a. If minimum 8'0" OH is not possible, consult Inclinator, or EC, about possible solutions.
4. **Rail Wall Requirements:**
 - a. Single steel guide rail (provide by Inclinator) to be mounted to a 2"x12" plank, #1 fir or better.
 - b. Plank to be installed plumb and straight and shall securely hold the guide rail in a plumb and straight position regardless of car loading.
 - c. Guide rail shall be capable of supporting the loads imposed. Plank shall be fastened with (2) 3/8"x5" lags every 2' OC located at the edge of the plank. Countersink lag heads. 4"x4" studding, or equivalent, behind plank. See drawing detail.
 - d. Studs in rail wall must be of wood unless alternative steel studding is used that contains an inner wood section of equal strength. Studs shall be located per drawing.
 - e. Consult factory or local dealer for concrete or steel framed construction.
5. **Stabilizer system requirements:** In line studs for stabilizer are to be located opposite rail wall unless code 1 or 2, see drawings.
6. **ASME 17.1 Part 5.3:** Hoistway to be constructed in accordance with this code and all local codes. It is the responsibility of the GC and the EC to comply with all appropriate codes.



Hoistway Elevation

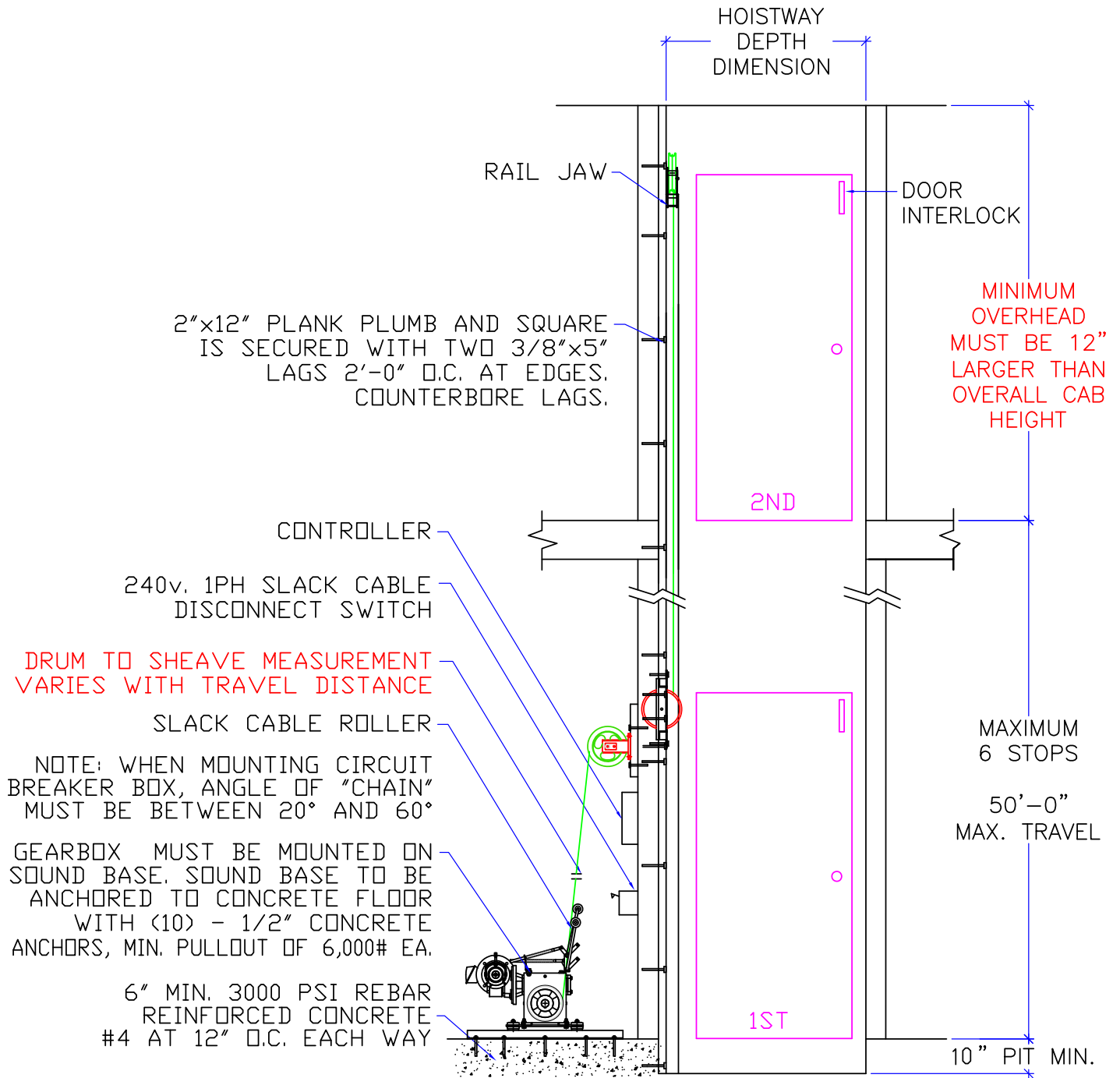

Pit Specifications

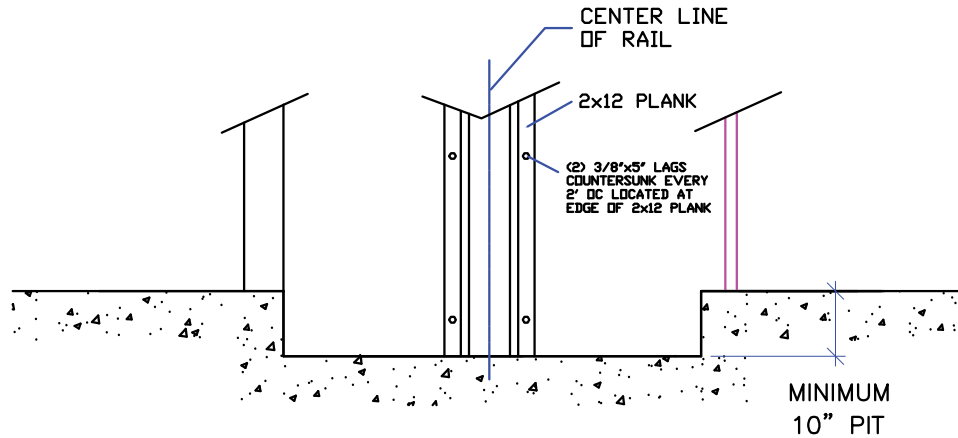

6" MINIMUM 3000 PSI REINFORCED CONCRETE #4 AT 12" O.C. EACH WAY.

Technical Specifications

1. VERTICAL LOAD FORCES
STATIC = 1,350 LBS
IMPACT = 2,700 LBS.
2. BOLT FASTENING OF CAR
TO TROLLEY 1/2" - 13 x 4"
SOCKET HD CAP SCREWS
3. RAIL FASTENING TO 2"x12" PLANK
#14 x 1 3/4" TYPE A S.M.S.
RAIL IS PRE-DRILLED AT FACTORY
4. ALL SHEAVE DIA. 8 5/16"



Machine Room Specifications

1. Permanent 230 volt, single phase, 30 amp power to operate the elevator.
Inclinor will provide a lockable circuit breaker disconnect switch with auxiliary contacts for battery lowering.
2. 120 volt lighting supply and disconnect by others.
3. Machine room area to meet local and national codes.
4. Machine room must be lockable by code.
5. Telephone connection: Code requires a telephone connection. A phone line must be installed leading to the controller.
6. N.E.C. Regulations
 - a. Minimum 30" x 36" clear unobstructed floor space in front of controller.
 - b. Minimum Floor to ceiling height of control room 6' 6"
7. The temperature should be maintained between 40⁰F – 60⁰F and should not be exposed to the elements.

NOTE:
MACHINE ROOM LAYOUT MUST COMPLY WITH LOCAL, STATE, AND NATIONAL CODES. REVISE AS NECESSARY FOR COMPLIANCE IN YOUR AREA.

NOTE:
MACHINE ROOM TO HAVE NATURAL/ MECHANICAL VENTILATION IF REQUIRED BY STATES OR LOCAL CODES.

NOTE:
FLOOR TO CEILING HEIGHT OF 6' 6"

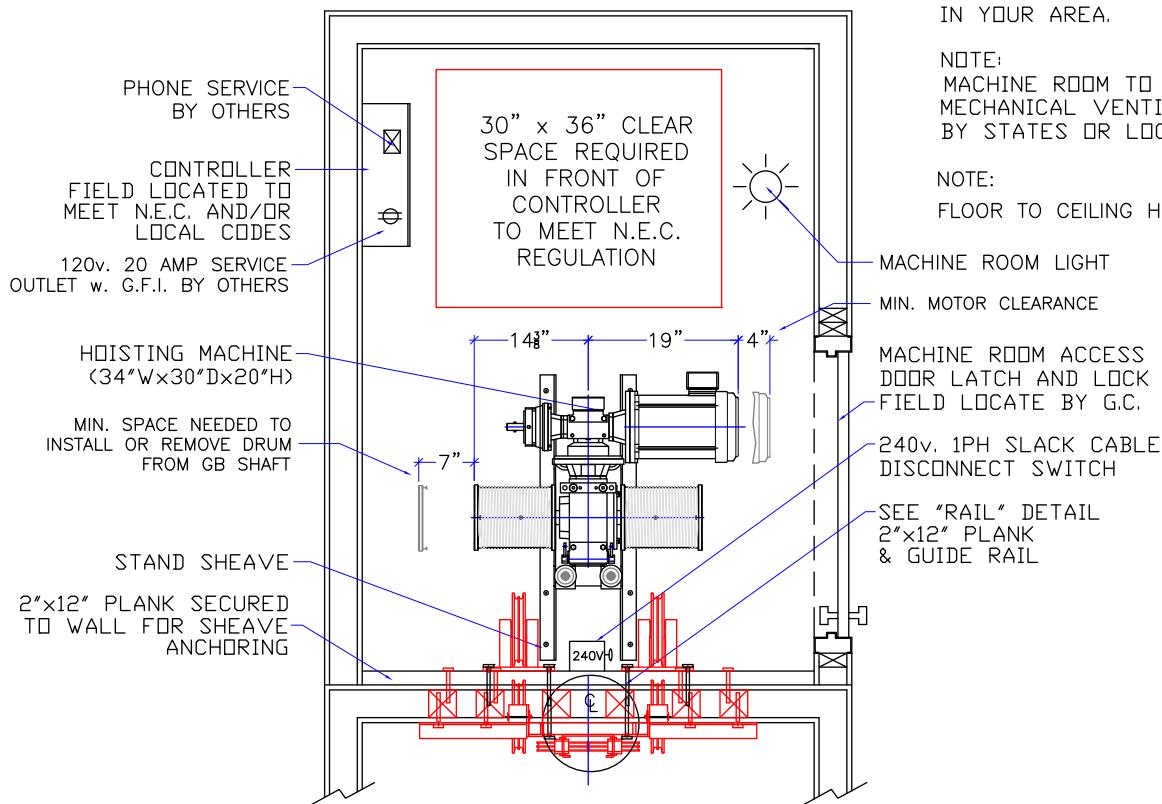

Machine Room Configurations

MACHINE ROOM ADJACENT

In this configuration the machine room is located either to the right or left of the main rail. Requires:

(3) Flat Bracket Sheaves

(1) Rail Jaw

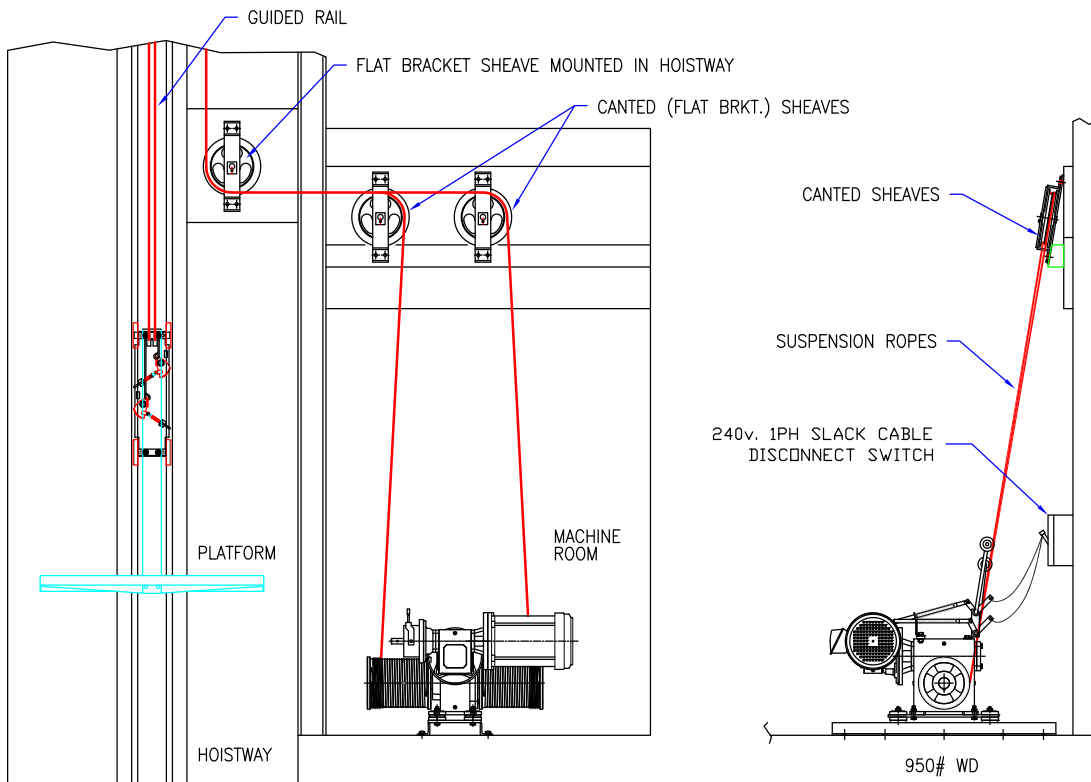
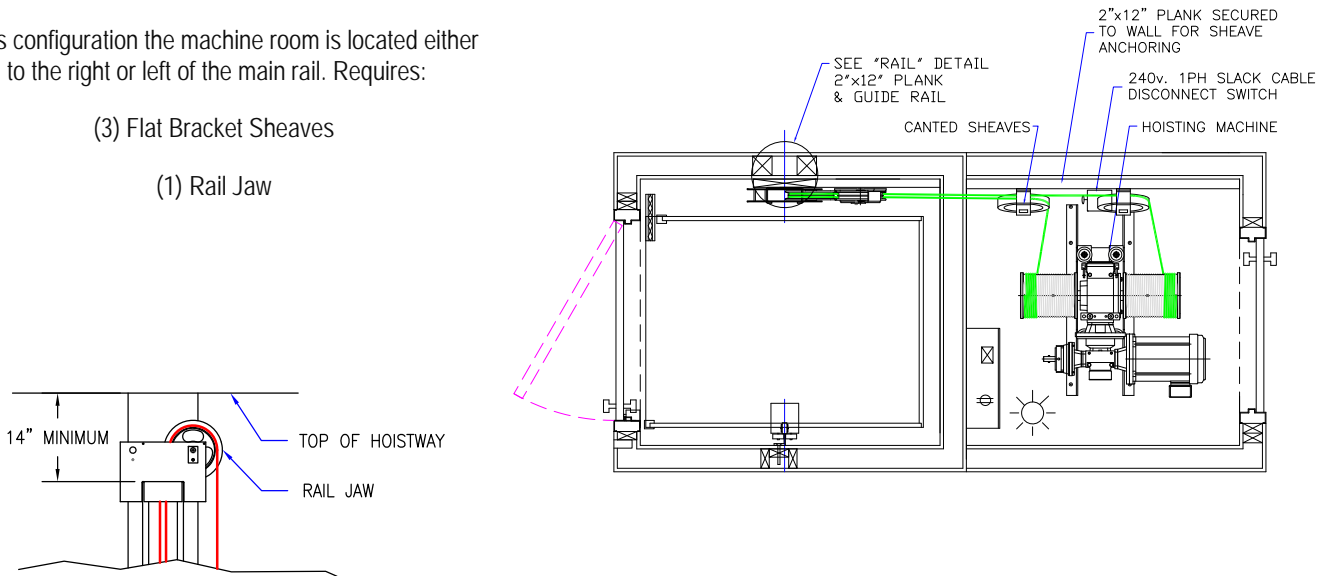

Machine Room Configurations

MACHINE ROOM BEHIND RAIL

In this configuration the machine room is located directly behind the main rail. Requires:

- (2) Stand Sheaves
- (2) Flat Bracket Sheaves w/ Welded Angle
- (1) Rail Jaw

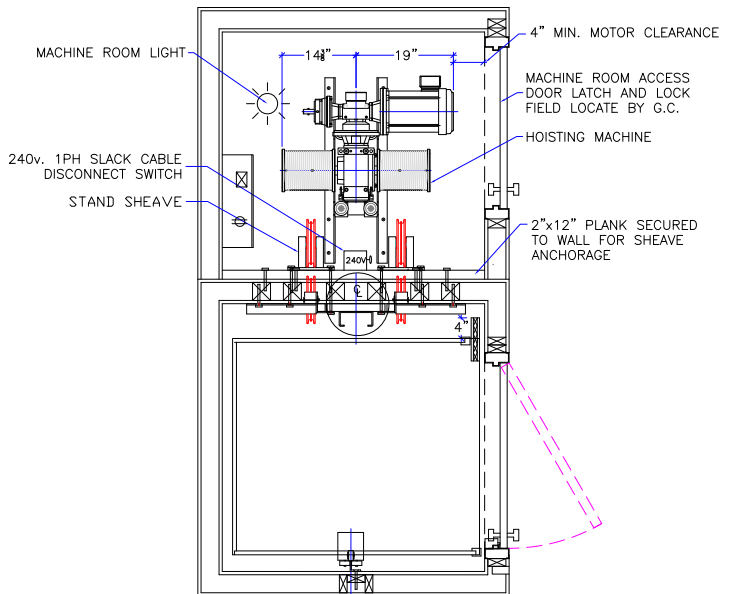
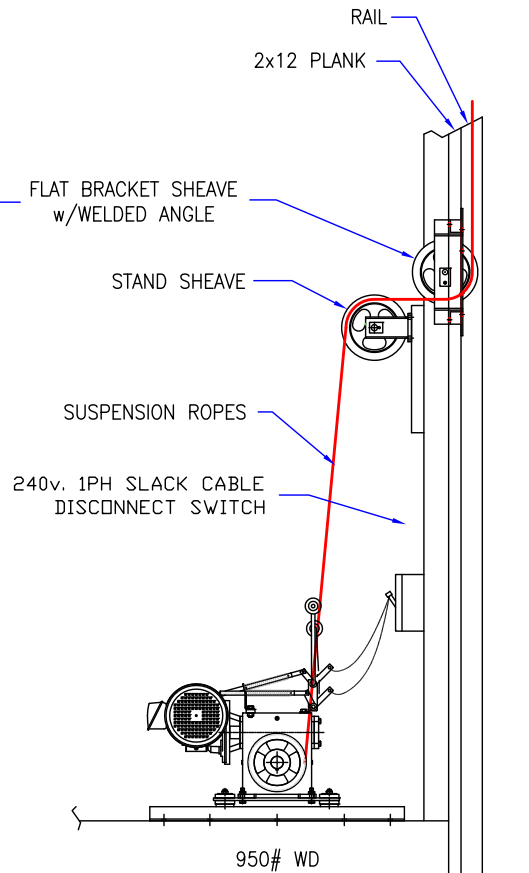
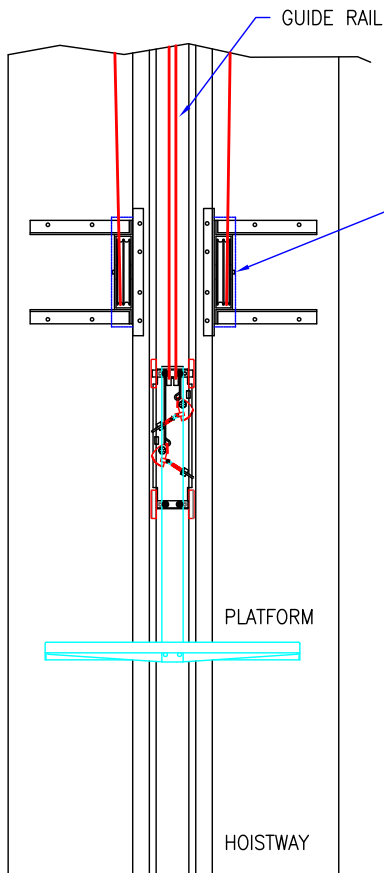
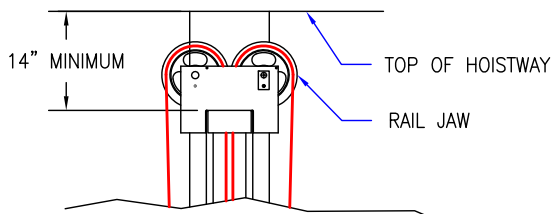

Machine Room Configurations

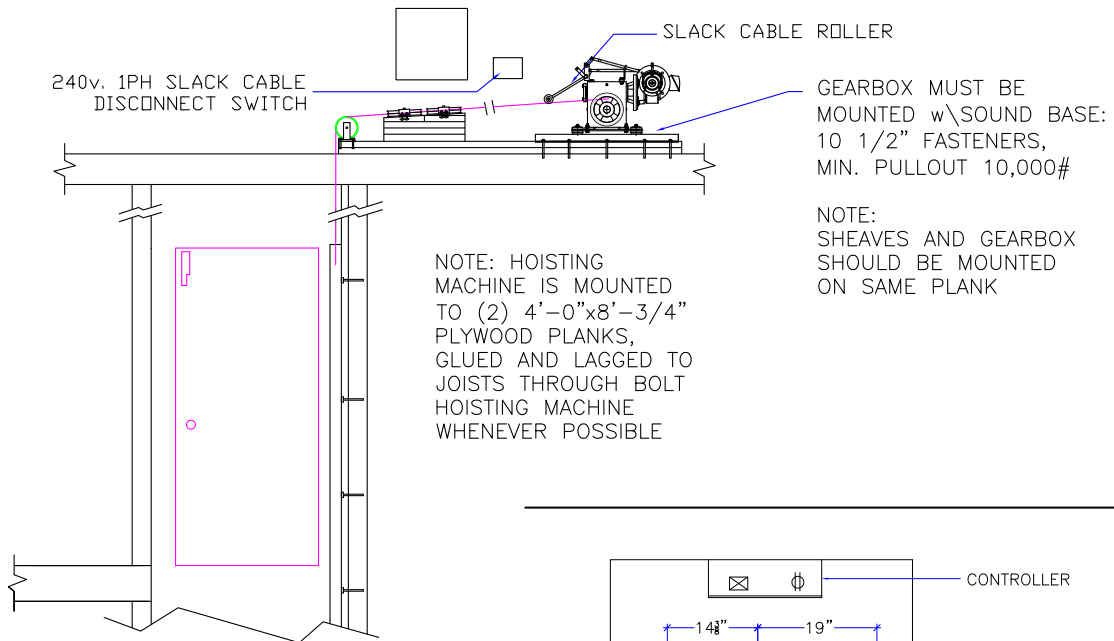

MACHINE ROOM OVERHEAD

In this configuration the machine room is located overhead in the attic. Requires:

- (2) Flat Bracket Sheaves
- (1) Stand Sheave

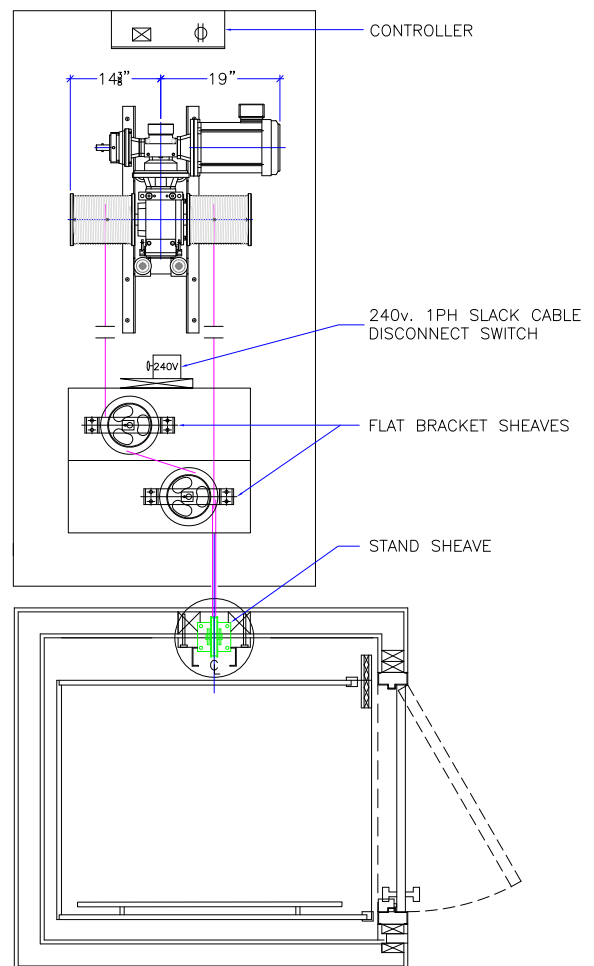

Gearbox Assembly

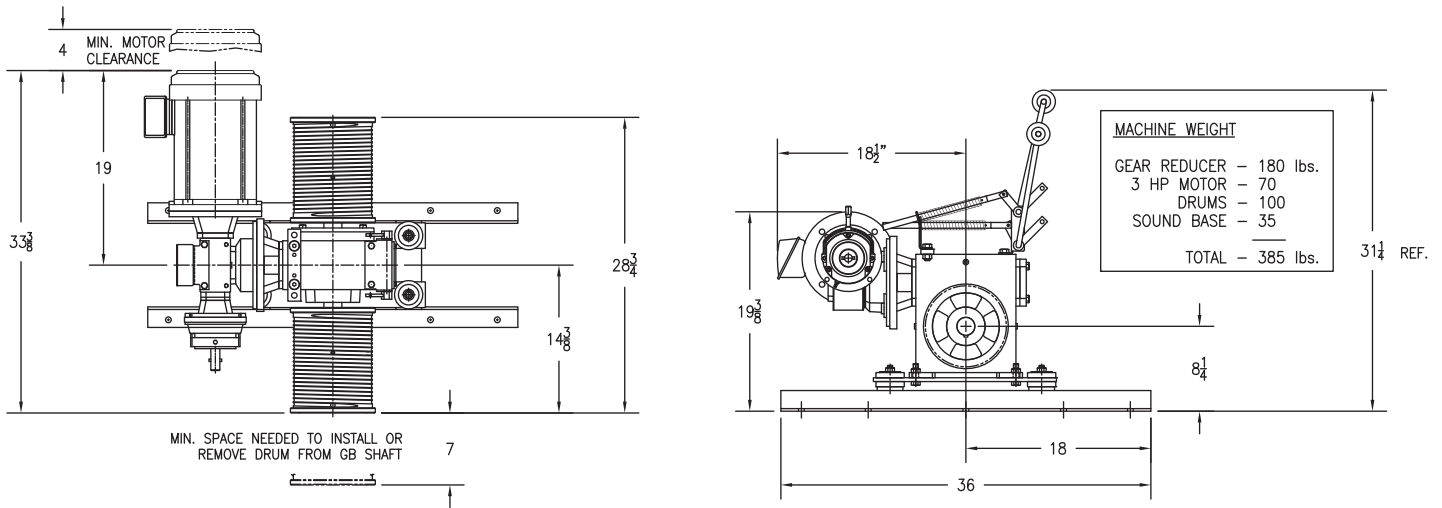

Travel Sheaves

Reactions on all sheaves rated at: 950# WINDING DRUM – 1800lbs.

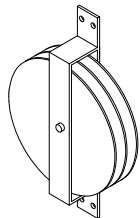

Flat Bracket Sheave

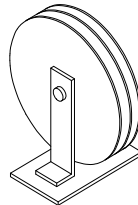

Stand Sheave

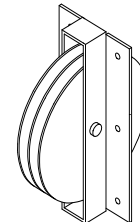

Center of Plank Sheave

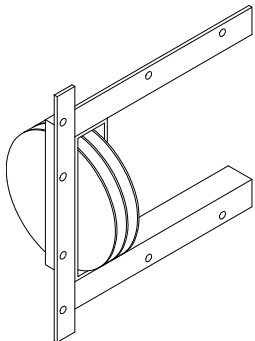

Flat Bracket Sheave With Angle

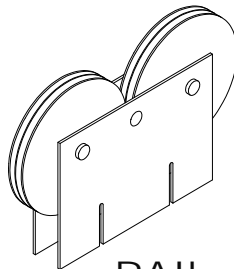

RAIL JAW

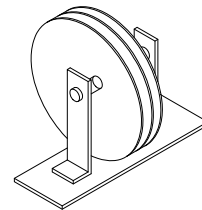

Floating Stand Sheave



Warranty

This warranty and all implied warranties including the implied warranties of merchantability and fitness for a particular purpose, for this product are limited to a period of two years from the time this product is first installed.

Some states do not allow limitations on how long an implied warranty lasts, so the above limitation may not apply to you.

The manufacturer is not responsible for consequential damages resulting from the use of this product, including labor charges for removal and reinstallation of parts. The manufacturer's liability for any damages resulting from use of this product or breach of this or any implied warranties is limited solely to parts, repair or replacement in accordance with the terms set forth above and these are the exclusive remedies available to purchasers of this product.

Some states do not allow the exclusion or limitation of incidental or consequential damages, so the above limitation or exclusion may not apply to you.



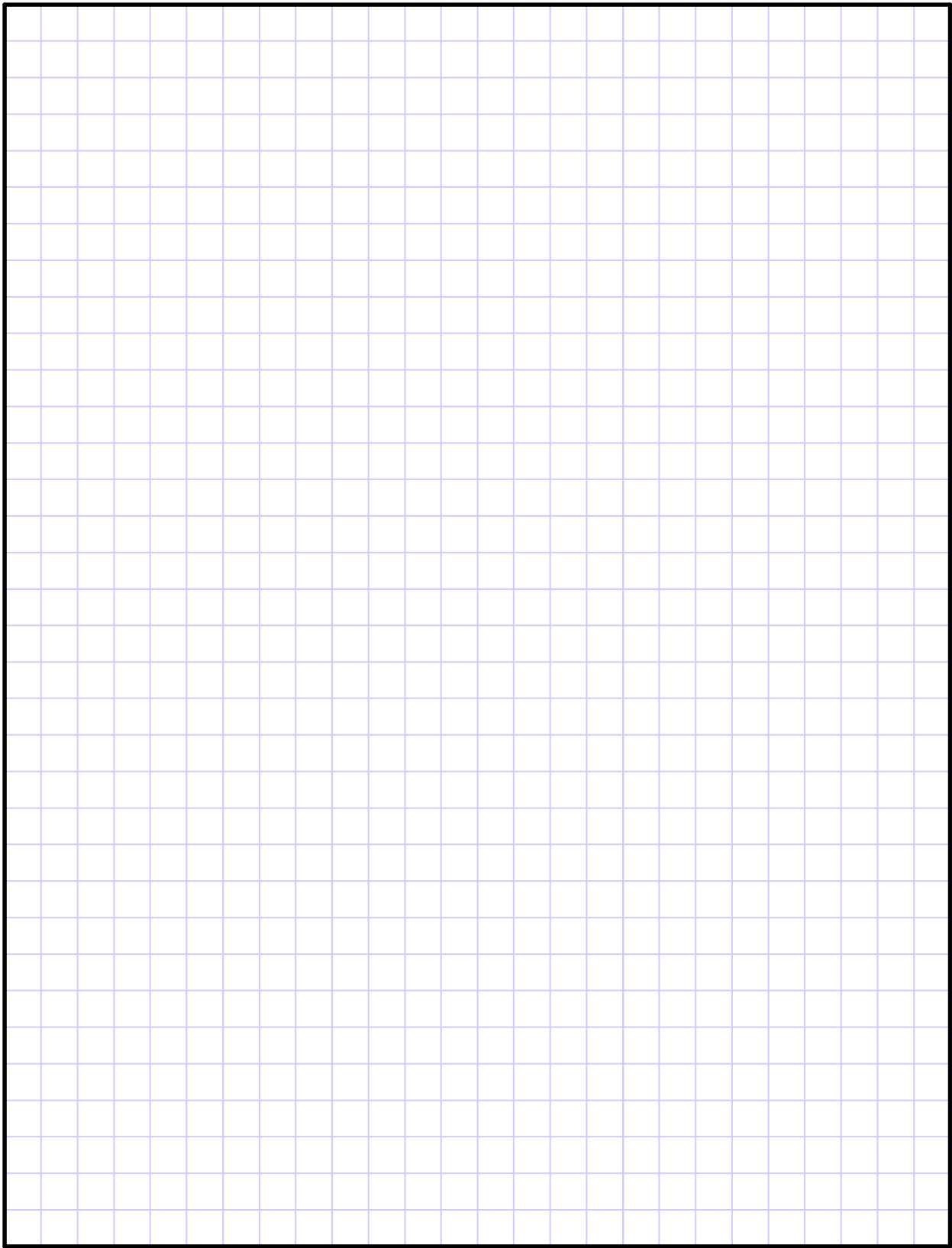

601 Gibson Blvd, Harrisburg, PA 17104 | 800-343-9007 | www.INCLINATOR.com

